

UVM ScholarWorks

Use of Artificial Nest Boxes by American Kestrels (*Falco sparverius*) in Western Vermont

Item Type	undergraduate thesis
Authors	Yaros, Grace
Download date	2026-06-16 09:32:30
Item License	http://creativecommons.org/licenses/by-nc-nd/3.0/
Link to Item	https://hdl.handle.net/20.500.14849/5551

Use of Artificial Nest Boxes by American Kestrels (*Falco sparverius*) in Western Vermont

Grace Yaros

Wildlife and Fisheries Biology, Honors College

Defense Committee: Dr. Allan Strong, Margaret Fowle & Michael McDonald

Abstract

American Kestrels (*Falco sparverius*) have been experiencing population declines in North America in recent decades, likely due to increased urban development and the subsequent loss of grassland habitat and standing dead trees that provide cavities in which they nest. In populations where nest sites are a limiting factor, artificial nest boxes have been used to increase an area's carrying capacity. The goal of this project was to investigate if and how nest boxes in western Vermont are used by kestrels. An experimental and control area were selected, and kestrel population surveys were conducted in both areas before and after nest box installation. Fourteen nest boxes were set up in Ferrisburgh, Vermont. Nest boxes were placed at least 0.8 km apart and were spread across an area of about 18 km². Despite kestrels being present within the experimental area, none of the nest boxes were used by kestrels. There are several potential reasons for this result. First, it is possible that nest cavities were not a limiting resource for this population. Second, more time may have been needed to allow the kestrels to acclimate to the boxes and recognize them as potential nesting sites. And third, there were factors important to kestrels that were not considered during nest box placement, such as the type of field surrounding the nest box. In the future, a more thorough examination of active kestrel nest sites in the area would help to determine what factors affect nest site selection for this population. Additionally, continued monitoring of nest box use over a longer time period would inform additional work.

Introduction

The American Kestrel (*Falco sparverius*), hereafter kestrel, is North America's smallest falcon. These petite, multicolored falcons inhabit swaths of open areas with sparse trees. Open fields are needed for hunting insects and small rodents, while trees are required as a source of nest cavities, making kestrels rather specialized in their habitat requirements. Kestrels are secondary cavity nesters, meaning that they don't excavate their own cavities, but instead use natural cavities or cavities created by other species, such as Pileated Woodpeckers (*Dryocopus pileatus*); the presence of cavity-excavators is therefore also a crucial component of kestrel habitat. Although these species are important in creating cavities that kestrels rely on, woodpeckers and other cavity-nesting species such as European Starlings (*Sturnus vulgaris*) and gray squirrels (*Sciurus carolinensis*) can create competition for nest cavities. Kestrels have been known to harass and outcompete many other cavity-nesting birds, but apparently cannot successfully compete with squirrels for nest sites (Balgooyen 1976). Kestrel populations are limited predominantly by nest cavities, prey abundance, availability of perches from which to search for prey, and the amount of low, open vegetation (Balgooyen 1976).

In recent decades, populations of kestrels across North America have been experiencing declines (Smallwood et al. 2009a; Farmer & Smith 2009). In the Northeastern United States, kestrels have been declining since at least the 1990's (Farmer & Smith 2009). Migration counts of kestrels at Hawk Mountain in Pennsylvania indicate that the overall population trend from 1934-1986 was stable, but when the scale was narrowed to 1971-1986, migration counts showed a significant decrease in kestrel populations; this suggests that the current declines are a recent development (Bednarz et al. 1990). The decline of kestrels is thought to be largely impacted by a widespread decrease in pastures and fields as a result of urban development and increasingly

intensive agricultural practices (Bednarz et al. 1990; Renfrew 2013). Specifically, the loss of snags, and by extension the loss of potential nest sites, is one consequence of continued urban development (Wildlife Habitat Management 1999; Brown et al. 2014). Reforestation is also of concern to kestrel populations as many fields become forested and thus unavailable for use by kestrels (Renfrew 2013).

Vermont, like the rest of the United States, has seen a decline in American Kestrel populations. Data from the North American Breeding Bird Surveys show a 2.09% decrease (95% CI = -3.55, -0.66) in the total number of kestrels detected per year along Vermont's survey routes from 1966-2019 (Sauer et al. 2020). The Vermont Breeding Bird Atlas project provides data on changes in species distribution over time. Field work for the first Atlas took place from 1977-1981, while field work for the second Atlas took place from 2003-2007. Between the two Atlases, the number of blocks in which kestrels were present during the breeding season decreased by 26%. This decline indicates a decrease in range and perhaps population size. (Renfrew 2013). According to data from the United States Department of Agriculture Census of Agriculture, the amount of dairy farm acreage and pasture acreage in Vermont decreased by 29% from 2002-2017 (as cited in Karen Karp & Partners 2020). This decrease in the amount of pastureland in Vermont likely corresponds to a decrease in the amount of open foraging habitat for kestrels. Because northern populations, including those in Vermont, are migratory and spend the winter months outside of Vermont, factors on wintering areas and along migration routes may also be contributing to their decline (Smallwood et al. 2009a).

Although urban development and intensive agricultural practices are changing landscapes across the state, open fields that provide spaces for kestrels to hunt in are still abundant throughout Vermont. If fields for foraging sites are available, a lack of available nesting cavities

may be driving the decline of kestrels in Vermont. Artificial nest boxes have been used as a tool to monitor and combat population declines for many cavity-nesting species, including American Kestrels. Artificial nest boxes increase the number of available cavities in an area and provide a means to estimate and monitor population trends, making them crucial tools in the management of declining cavity-nesting species. Nest box occupancy and fledging success of American Kestrels using nest boxes are generally high (Hamerstrom et al. 1973; Toland & Elder 1987; Katzner et al. 2005; Rusboldt et al. 2006; Smallwood & Collopy 2009a; Shave & Lindell 2017a). The goal of this project is to evaluate the use of artificial nest boxes by American Kestrels in Vermont. There is no previous research on kestrel nest box use in Vermont, and my project seeks to fill this knowledge gap.

Methods

Kestrel Surveys

I conducted roadside surveys around the experimental area in June of 2021 (pre-nest box surveys) to estimate kestrel density before nest box installation and again in the same locations in June of 2022 after nest boxes had been installed (post-nest box surveys) to examine if and how kestrel population density changed in response to nest box installation. These surveys were based on the US Geological Survey Breeding Bird Survey methodology: during these surveys, the vehicle was stopped every 0.8 kilometers, and the number of raptors seen during the 3-minute survey period was recorded. This methodology was selected to survey kestrels due to their tendency to perch conspicuously and hover over fields while hunting, making them relatively easy to detect along roadsides. I also noted Pileated Woodpecker presence, as the holes they create can provide natural cavities for kestrels.

I used the same protocol to conduct kestrel population surveys in a control area, also in June 2021. Control surveys were conducted in Vergennes, Vermont, at a minimum distance of 5 kilometers away from the nest boxes. Each of the survey points were conducted in suitable kestrel habitat. I selected this location to conduct the control surveys because the surrounding habitat consisted of open fields similar to the experimental area. Proximity to the experimental area was also considered to ensure that the two sites were as comparable as possible but were conducted far enough away from the study area that the study area's nest boxes would not have any impact on kestrel presence and subsequent data collection in the control area. Thirty points were surveyed in the experimental and control area.

Nest Box Installation

Fourteen nest boxes were placed on public and private land in Ferrisburgh, Vermont in early June of 2021. Nest boxes were placed facing open fields, and I noted the species of tree each nest box was mounted to, as well as the land cover surrounding each nest box (grass, corn, etc.). Although the land cover of the field adjacent to each nest box was noted, crops in the experimental area are rotated frequently, so these data note the land cover during nest box installation, and do not account for crop rotation at locations that are actively farmed land.

Nest boxes were spaced at least 0.8 kilometers apart from each other, in accordance with another local project involving kestrel nest boxes (B. Lowe, personal communication, October 21, 2020). Nest box locations were selected based on approximate field size, availability of sufficiently tall trees with high visibility, and where I was able to obtain permission to set up nest boxes (landowners were visited in person and given a letter describing the project; see Appendix C). Of the fourteen nest boxes, the smallest field immediately surrounding a nest box was

approximately 0.06 km². The other nest boxes were placed next to fields significantly larger than this, and all nest boxes were placed next to fields that were connected to additional fields, so the amount of foraging habitat actually available to kestrels was much larger than the size of the fields the nest boxes were placed in.

Generally, when selecting a nest site, kestrels select for factors such as level of concealment around the site, tree diameter, and nest height (Spiegel 1975; Rohrbaugh & Yahner 1997). An effort was made to place the nest boxes in highly visible locations to encourage discovery by kestrels. Nest boxes were mounted at least 3 meters high, in accordance with a local project and previous research (Hamerstrom et al. 1973; Rohrbaugh & Yahner 1997; Katzner et al. 2005; Butler et al. 2009; B. Lowe, personal communication, October 21, 2020; Kamm & Reed 2020).

I did not consider nest box orientation during installation. The relationship between orientation of a nest box, occupancy of the nest box by kestrels, and nesting success is complex; some studies have shown that orientation has no impact on occupancy or success of a nest box (Greenwood & Dawson 2011; Kamm & Reed 2020), others have shown that certain orientations do produce greater occupancy but have no impact on nesting success (Rohrbaugh & Yahner 1997), and some have found that kestrels have a significantly greater proportion of unsuccessful nesting attempts in southwest-facing boxes than other orientations (Butler et al. 2009).

Nest boxes were installed one year before nest box monitoring began in order to allow kestrels to discover these nest boxes during post-fledging dispersal and again during fall migration and spring migration. This sequence provided an opportunity for nest box discovery during three movement periods prior to monitoring.

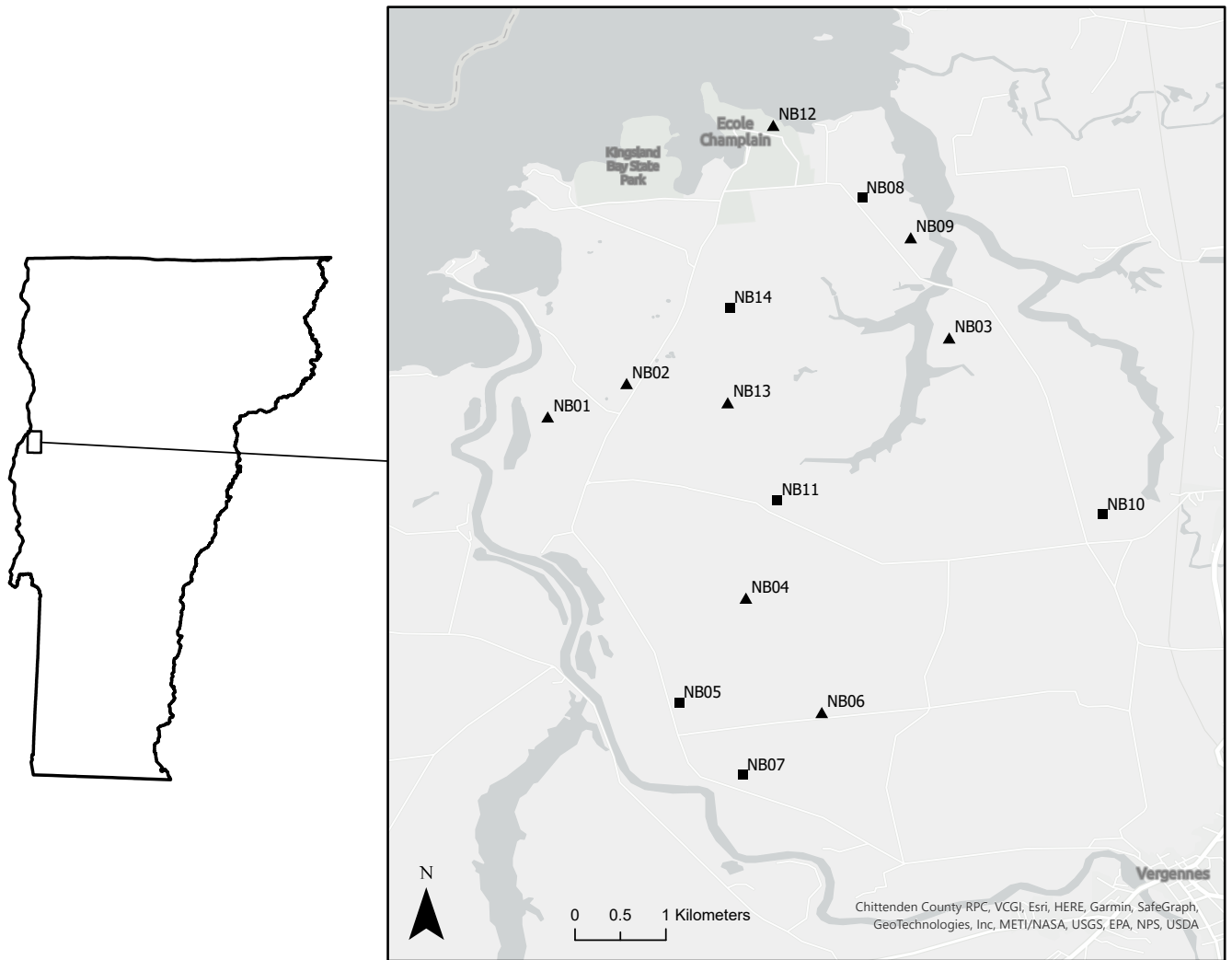

Figure 2: Map of American Kestrel nest box locations in Ferrisburgh, Vermont. A total of 14 nest boxes were erected in June 2021 and monitored for nesting activity in June 2022. Trail cameras were placed outside of NB01, NB02, NB03, NB04, NB06, NB09, NB12, and NB13. Nest boxes with trail cameras are marked by triangles, all other nest boxes are marked by squares. Vermont state boundary layer from Vermont Open Geodata Portal.

Data Collection

All nest boxes were monitored for kestrel presence in June 2022. The inside of each nest box was first observed through the entry hole to determine if the nest box was being actively used; if a box was not in use, the side panel was then opened to examine its contents. During the winter of 2022, I placed trail cameras outside of eight of the nest boxes—NB01, NB02, NB03, NB04, NB06, NB09, NB12, and NB13—with the goal of monitoring kestrel prospecting activity around these boxes. I also retrieved photos from the trail cameras as nest boxes were monitored for nesting activity.

Nest Box Construction

I constructed 14 nest boxes using primarily larch wood (*Larix* sp.). The nest box design was loosely based on the design from Wildlife Habitat Management Institute (1999). Larch was selected due to its resistance to decay. A handful of pieces were constructed from eastern white pine (*Pinus strobus*) due to an insufficient supply of larch boards. The front pieces of the boxes were 30.5 cm x 40.6 cm, with a 7.6 cm diameter entry hole. Side panels were 30.5 cm in width and cut at an angle sloping toward the front of the box (exact dimensions in Fig. 1). Roofs and floors were 30.5 cm x 30.5 cm; roofs were trimmed as necessary to adjust for the sloped sides so the roofs lay flat along the tops of the sides. Back panels were 30.5 cm x 66 cm. Boxes were secured to trees using screws. The floor of each nest box was covered with a layer of wood shavings.

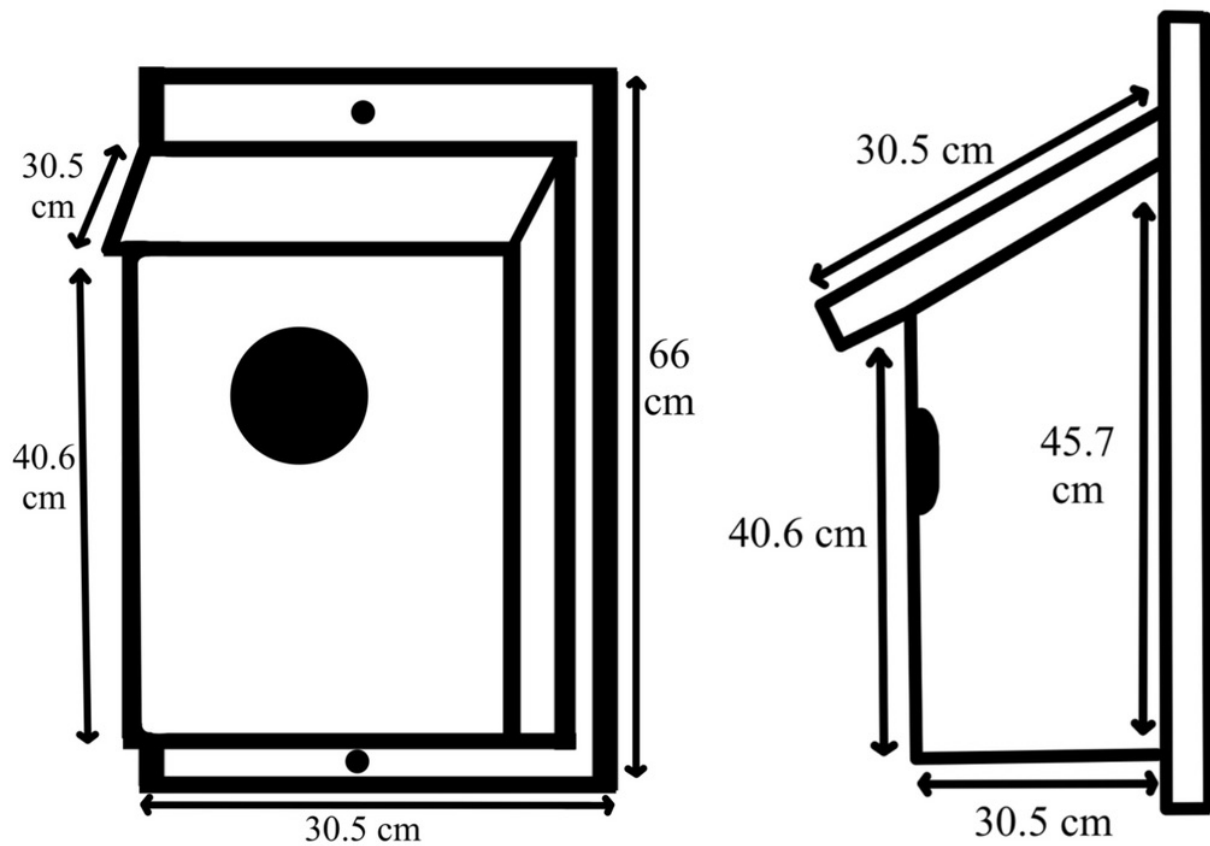

Figure 1: Illustration of nest box design used.

Results

Kestrel Surveys

No kestrels were detected during the pre-nest box surveys in the experimental area. During post-nest box surveys, one pair of kestrels was seen together at survey point 7, and one of the members of this pair was detected near the same location during the previous survey point just a few minutes before (Appendix A1). Although detected during two separate survey points, because these individuals were seen in the same location just minutes apart, I concluded that only 2 individuals were detected during pre-nest box surveys in the experimental area, and that the individual detected during survey point 7 did not represent a third individual. This pair was

consistently seen near this location throughout nest box monitoring and trail camera data retrieval. Though no nest cavity or juveniles were detected, the male was seen carrying prey, though he shortly flew out of sight. The pair was observed in fairly close proximity to NB08.

Based on observations throughout the time spent in the experimental area, including during surveys and setting up nest boxes, it was estimated that up to three pairs of kestrels were using the experimental area during this project.

In the control area, one kestrel was detected during pre-nest box surveys. No kestrels were detected in this area during post-nest box surveys (Appendix A2).

Nest Box Use

None of the 14 nest boxes had evidence of use by kestrels. During nest box monitoring, I discovered the snag to which NB14 was attached had fallen. Appendix B summarizes the surroundings of each nest box, as well as notes on use of each box.

Great Crested Flycatcher (*Myiarchus crinitus*) activity was detected at two of the nest boxes, NB01 and NB12. During monitoring, NB12 was being used for nesting; an adult was seen flying out of the nest box, and vocalizations were heard around the nest box while data from the camera were collected. To limit disturbance to the adults and young, this nest box was not opened during monitoring. NB01 contained a Great Crested Flycatcher nest that had apparently been abandoned. The trail camera outside of this nest box detected Great Crested Flycatchers both inside and around the nest box beginning in mid-May. The camera captured photos of at least one individual repeatedly entering and leaving the nest box, and in one of these photos the bird was carrying nesting material. No flycatchers were present at this box during monitoring, nor was there any evidence that activity at this nest box progressed beyond nest building.

NB11 was used by Tree Swallows (*Tachycineta bicolor*). An adult flew out of the box during monitoring, and young chicks were seen inside the box.

European Starlings (*Sturnus vulgaris*) were detected by the trail camera outside NB09. At least one bird was photographed inside the nest box around late April, but by mid-May, there was no activity inside the nest box. During monitoring, feathers and some nesting material were found inside the nest box, but there was no evidence of a full nesting attempt. The head of a starling was found inside of NB08 during monitoring. NB08 also contained what appeared to be an abandoned starling nest, containing five pale greenish eggs. A flock of starlings was photographed at NB03 in early March, and one of these individuals was photographed entering the nest box, though they were not detected at this box after this instance.

NB03, NB10, and NB06 all contained what appeared to be gray squirrel nests and were presumably used for shelter during the winter. The trail camera placed outside of NB06 captured a gray squirrel repeatedly entering the box from late March into late April and was photographed carrying leaves into the nest box.

NB02 contained an owl pellet and shredded bark, but there was no evidence of nesting activity in this nest box.

Discussion

Kestrel Surveys

The number of kestrels that I detected during the point count surveys in the experimental area increased after nest box installation. However, because the increase was from 0 to 2, there is no way to determine if this increase is statistically significant or a result of nest box presence. As a result of spending overall more time in the experimental area relative to the control area (due to

additional time spent conversing with landowners and setting up nest boxes), we have a better idea of the number of kestrels using the experimental area. None of the kestrels in the experimental area were detected during the pre-nest box surveys, indicating that detection during surveys does not necessarily reflect true presence. Future studies may consider adjusting the survey methods to allow for a more accurate representation of kestrel presence.

The number of kestrels detected in the control area decreased from 1 individual during the pre-nest box surveys to 0 individuals during post-nest box surveys. As with the experimental surveys, it is not possible to determine the significance of this change.

Nest Box Use

There are several potential reasons why the nest boxes were not selected by kestrels. Although the nest boxes were set up with the intention of allowing kestrels sufficient time and multiple opportunities to discover them, it is possible that kestrels need longer than one year to discover and use new nesting sites. It is also possible that the population of kestrels in this area has reached its carrying capacity based on factors other than cavity availability. Thus, young birds raised in the experimental area would be incentivized to disperse to an area with more available resources, and individuals looking to nest in the experimental area would have to compete with the breeding pairs already present.

Potentially, the pairs of kestrels present in the experimental area nested in available cavities present prior to nest box installation throughout the duration of the study. One study on kestrels using nest boxes in Idaho found that individuals tended not to select the same nest box across multiple years (Steenhof et al. 2009), though another study in Pennsylvania found that kestrels tended to choose the same next box again the next year, especially if the selected nest box

produced greater fledgling success (Katzner et al. 2005). Nest site fidelity in kestrels is likely varied and dependent on numerous factors. However, both studies found that kestrels generally did not nest in the same nest box for more than two consecutive years. Given the relatively short timeframe of this study, it is possible that the kestrel pairs present in the experimental area selected the same cavities both years and did not seek out new nest sites.

A more in-depth search for natural nest cavities may provide additional information. Locating natural cavities within the experimental area was not a focus of this project, and although there were kestrels living and presumably nesting in the experimental area, the location of these nests and the number of natural cavities in the experimental area is unknown. Natural cavities may be sufficiently abundant in the experimental area, and local breeding kestrels may therefore already have readily available nest sites and have no need to use a relatively unfamiliar nest cavity. The addition of nest boxes has been found to be ineffective at helping to increase the population density of cavity-nesting animals, including kestrels, if nesting sites are not a limiting factor for that population (McClure et al. 2017; Shave & Lindell 2017b). If nesting cavities are not a limiting factor for this population of kestrels, there would likely be less incentive for these kestrels to shift from nesting in a natural cavity to nesting in an unfamiliar, artificial cavity, possibly explaining the lack of use of these nest boxes. Understanding where these kestrels are nesting may provide additional insight as to why these nest boxes were not selected by kestrels and may also provide important information on the many factors that influence nest site selection. By taking a closer look at nest sites that kestrels *are* using, we can use that information to inform future nest box placement in Vermont.

It is possible that there are factors other than nest site availability that may be limiting for this population; prey availability is certainly one factor that could be limiting. Predation could also be

limiting this population; Red-tailed Hawks (*Buteo jamaicensis*) and Cooper's Hawks (*Accipiter cooperii*) were both detected in the experimental area (Appendix A1), and both are known to hunt small birds.

Additionally, it is likely that there are factors that were not considered during nest box placement but are important in nest site selection. Among many potential factors, prey availability, intraspecific and interspecific competition, and predator avoidance are all likely to influence nest site selection but were not taken into consideration during nest box installation. Most of the nest boxes were placed adjacent to corn fields; it is possible that corn fields provide lower-quality foraging habitat for kestrels than hay or grass fields by supporting a lower diversity and/or abundance of prey. The proximity of these nest boxes to a relatively low-quality habitat could have encouraged kestrels to select alternative nest cavities.

Although the nest boxes were not used by kestrels specifically, most of the nest boxes were used in some manner, whether for nesting and raising young or for shelter from the elements. Local wildlife benefitted from the presence of the nest boxes. The fact that these nest boxes were used suggests that nest cavities may be limiting for cavity-dependent species living in the experimental area.

Given the scale of the landscapes that kestrels inhabit throughout the course of the year, the conservation of migratory species, including kestrels, is complex; effective conservation measures require collaboration across multiple scales to identify threats and implement conservation actions throughout their range. Efforts to conserve the open habitats that kestrels need will also benefit a variety of other species, including other grassland species and species that rely on cavities, such as woodpeckers and owls. A previous study that modeled American Kestrel nest box occupancy in Florida relative to local landscape structure concluded that habitat

fragmentation led to decreased persistence at a nest site at a fine landscape scale. The authors suggested that fragmented habitats may support species such as gray squirrels, European Starlings, Eastern Screech-Owls (*Megascops asio*), and raccoons (*Procyon lotor*) that negatively impact kestrel reproductive success by removing kestrels from cavities or preying upon kestrel eggs or nestlings (Brown et al. 2014). Another study found that kestrels in New Jersey selected nest boxes in patches of contiguous suitable habitat greater than 1,000 hectares significantly more frequently than nest boxes in smaller patches. Using ArcGIS and a landcover dataset, the authors identified a total of eleven land use and landcover categories that were determined to be suitable kestrel foraging habitat, all of which were open areas with herbaceous vegetation. The authors verified patch boundaries in the field, and adjusted patch boundaries as necessary (Smallwood et al. 2009b).

Future research could involve continued monitoring of the nest boxes over a longer time period. Continued monitoring would provide information on how nest box use changes over time. Determining which nest boxes kestrels are successfully raising young in and collecting data on microhabitat characteristics at those boxes could inform future nest box placement in Ferrisburgh and perhaps other locations in Vermont; for example, comparing occupancy and/or fledging success of kestrels in nest boxes adjacent to corn fields to nest boxes next to hay fields. Another possible extension of this project could involve setting up additional nest boxes outside of Ferrisburgh and comparing use by kestrels of those nest boxes to the nest boxes in Ferrisburgh.

As demonstrated by their use of artificial nest boxes and their willingness to hunt over farm fields, American Kestrels will use human-altered landscapes. This offers a ray of hope as we work to mitigate their population declines: kestrels can, and will, exist in altered landscapes,

provided the necessary resources are available to them. The use of artificial nest boxes is not a replacement for identifying and working to remedy the underlying causes of American Kestrel population declines, but when implemented properly, nest boxes can be a valuable tool to help offset some of these declines.

Acknowledgements

I would like to express my many thanks to Ray Brands, Brett Danyow, Randy Cameron, Moriah Sullivan, Ryan Fortune, and the staff at Little Otter Creek Wildlife Management Area and Kingsland Bay State Park for hosting these nest boxes, without whom this project would not have been possible. Additional thanks to the UVM Office of Fellowships, Opportunities & Undergraduate Research for supplying funding for the materials used to construct these nest boxes. I also wish to acknowledge and thank the thousands of participants involved in collecting data for the North American Breeding Bird Survey. Lastly—but certainly not least—I would like to thank my advisor Dr. Allan Strong for his feedback and guidance throughout this project, and my committee members Margaret Fowle and Michael McDonald for their insights. This research was approved by the University of Vermont Institutional Animal Care and Use Committee (Protocol # PROTO202100075) and monitoring of nest boxes was conducted under a Vermont Fish and Wildlife Department Scientific Collection Permit (Authorization # SR-2022-07).

Reference List

- Balgooyen, T. (1976). *Behavior and ecology of the American kestrel (Falco sparverius L.) in the Sierra Nevada of California*. (Vol. 103). University of California Press.
- Bednarz, J. C., Daniel Klem, J., Goodrich, L. J., & Senner, S. E. (1990). Migration counts of raptors at Hawk Mountain, Pennsylvania, as indicators of population trends, 1934-1986. *The Auk*, *107*(1), 96-109.
- Brown, J. L., Collopy, M. W., & Smallwood, J. A. (2014). Habitat fragmentation reduces occupancy of nest boxes by an open-country raptor. *Bird Conservation International*, *24*(3), 364-378.
- Butler, M. W., Whitman, B. A., & Dufty, A. M. (2009). Nest box temperature and hatching success of American kestrels varies with nest box orientation. *Wilson Journal of Ornithology*, *121*(4), 778-782.
- Farmer, C. J., & Smith, J. P. (2009). Migration monitoring indicates widespread declines of American kestrels (*Falco sparverius*) in North America. *Journal of Raptor Research*, *43*(4), 263-273.
- Greenwood, J. L., & Dawson, R. D. (2011). Nest- and territory-scale predictors of nest-site selection, and reproductive investment and success in a northern population of American kestrels (*Falco sparverius*). *Ecoscience*, *18*(2), 145-156.
- Hamerstrom, F., Hamerstrom, F. N., & Hart, J. (1973). Nest boxes: An effective management tool for kestrels. *Journal of Wildlife Management*, *37*(3), 400-403.
- Kamm, M., & Reed, J. M. (2020). Assessing microhabitat characteristics as predictors of nest-box occupancy in a declining bird species, the American kestrel (*Falco sparverius*). *Northeastern Naturalist*, *27*(2), 344-357.

Karen Karp & Partners. (2020). *Vermont dairy marketing assessment*.

https://agriculture.vermont.gov/sites/agriculture/files/doc_library/KKP_VT%20Dairy%20Marketing%20Assessment0224.pdf

Katzner, T., Robertson, S., Robertson, B., Klucsarits, J., McCarty, K., & Bildstein, K. L. (2005). Results from a long-term nest-box program for American kestrels: Implications for improved population monitoring and conservation. *Journal of Field Ornithology*, 76(3), 217-226.

McClure, C. J. W., Pauli, B. P., & Heath, J. A. (2017). Simulations reveal the power and peril of artificial breeding sites for monitoring and managing animals. *Ecological Applications*, 27(4), 1155-1166.

Renfrew, R. B. (2013). *The Second Atlas of Breeding Birds of Vermont* (2nd ed.). University Press of New England.

Rohrbaugh, R. W., & Yahner, R. H. (1997). Effects of macrohabitat and microhabitat on nest-box use and nesting success of American kestrels. *The Wilson Bulletin*, 109(3), 410-423.

Rusbult, J. J., Klucsarits, J. R., Robertson, S., & Robertson, B. (2006). Reproductive success of American kestrels using nest boxes in eastern Pennsylvania, 1992-2005. *Pennsylvania Birds*, 20(3), 112-117.

Sauer, J. R., Link, W. A., & Hines, J. E. (2020). *The North American Breeding Bird Survey, Analysis Results 1966 - 2019* [Data set]. <https://doi.org/10.5066/P96A7675>.

Shave, M. E., & Lindell, C. A. (2017a). American kestrels occupying nest boxes in Michigan cherry orchards show high reproductive rates and tolerance of monitoring. *Journal of Raptor Research*, 51(1), 50-60.

- Shave, M. E., & Lindell, C. A. (2017b). Occupancy modeling reveals territory-level effects of nest boxes on the presence, colonization, and persistence of a declining raptor in a fruit-growing region. *PLoS ONE*, *12*(10), 1-12.
- Smallwood, J. A., Causey, M. F., Mossop, D. H., Klucsarits, J. R., Robertson, B., Robertson, S., Mason, J., Maurer, M. J., Melvin, R. J., Dawson, R. D., Bortolotti, G. R., Parrish, J. W., Breen, T. F., & Boyd, K. (2009a). Why are American kestrel (*Falco sparverius*) populations declining in North America? Evidence from nest-box programs. *Journal of Raptor Research*, *43*(4), 274-282.
- Smallwood, J. A., & Collopy, M. W. (2009). Southeastern American kestrels respond to an increase in the availability of nest cavities in north-central Florida. *Journal of Raptor Research*, *43*(4), 291-300.
- Smallwood, J. A., Winkler, P., Fowles, G. I., & Craddock, M. A. (2009b). American kestrel breeding habitat: the importance of patch size. *Journal of Raptor Research*, *43*(4), 308-314.
- Spiegel, S. (1975). *Nest site selection by the American kestrel, Falco sparverius* McGill University. Montreal, Quebec.
- Steenhof, K., & Peterson, B. (2009). Site fidelity, mate fidelity, and breeding dispersal in American Kestrels. *The Wilson Journal of Ornithology*, *121*(1), 12-21.
- Toland, B. R., & Elder, W. H. (1987). Influence of nest-box placement and density on abundance and productivity of American kestrels in central Missouri. *The Wilson Bulletin*, *99*(4), 712-717.
- United States Geological Survey (n.d.). *North American Breeding Bird Survey (BBS)*. <https://prd-wret.s3-us-west-2.amazonaws.com/assets/palladium/production/s3fs-public/atoms/files/BBS%20overview%202017.pdf>
- Wildlife Habitat Management Institute (1999). *American kestrel (Falco sparverius)*. https://www.nrcs.usda.gov/Internet/FSE_DOCUMENTS/nrcs144p2_014926.pdf

Appendix A

Table A1: Summary of American Kestrel (AMKE) surveys in the experimental area of Ferrisburgh, VT, before nest box installation (June 2021) and after nest box installation (June 2022). Pre-nest box surveys took place on June 10th and 12th, 2021. Post-nest box surveys took place on June 20th, 2022. Roadside surveys were conducted every 0.8 km, and all raptors seen during the 3-minute survey period were noted. The AMKE column summarizes the number of kestrels detected during each survey. TUVU=Turkey Vulture, BAEA=Bald Eagle, COHA=Cooper's Hawk, OSPR=Osprey, RTHA=Red-tailed Hawk, PIWO=Pileated Woodpecker, BLVU=Black Vulture, NOHA=Northern Harrier. *The individual detected at this point was one of the individuals detected at Point 7.

June 2021			June 2022		
Point	AMKE	Other	Point	AMKE	Other
1	0		1	0	
2	0	1 TUVU	2	0	
3	0		3	0	
4	0	1 BAEA	4	0	
5	0		5	0	
6	0	1 TUVU	6	1*	
7	0	1 TUVU	7	2	
8	0	1TUVU, 1 BAEA	8	0	
9	0		9	0	
10	0	1 OSPR	10	0	
11	0	1 OSPR, 2 RTHA	11	0	
12	0		12	0	
13	0	1 TUVU, 1 COHA	13	0	
14	0		14	0	
15	0	1 TUVU	15	0	
16	0	1 TUVU	16	0	
17	0	probable BAEA	17	0	
18	0		18	0	
19	0		19	0	
20	0		20	0	
21	0		21	0	
22	0		22	0	1 NOHA
23	0	1 OSPR	23	0	
24	0		24	0	
25	0		25	0	1 TUVU
26	0	1 RTHA	26	0	
27	0	1 PIWO, 1 BLVU, 1 TUVU	27	0	
28	0		28	0	9 TUVU
29	0		29	0	
30	0	1 TUVU	30	0	

Table A2: Summary of American Kestrel (AMKE) surveys in the control area of Vergennes, VT, before nest box installation (June 2021) and after nest box installation (June 2022). Pre-nest box surveys took place on June 22nd, 2021. Post-nest box surveys took place June 25th, 2022. Roadside surveys were conducted every 0.8 km, and all raptors seen during the 3-minute survey period were noted. The AMKE column summarizes the number of kestrels detected during each survey. TUVU=Turkey Vulture, RTHA=Red-tailed Hawk, PIWO=Pileated Woodpecker, NOHA=Northern Harrier, SSHA=Sharp-shinned Hawk.

June 2021			June 2022		
Point	AMKE	Other	Point	AMKE	Other
1	0		1	0	
2	0		2	0	
3	0		3	0	1 NOHA
4	0		4	0	
5	0		5	0	
6	0		6	0	
7	0		7	0	
8	0	1 RTHA	8	0	
9	0		9	0	
10	0		10	0	
11	0		11	0	
12	0		12	0	
13	0		13	0	
14	0		14	0	
15	0		15	0	
16	0		16	0	
17	0		17	0	
18	1		18	0	
19	0		19	0	
20	0	2 TUVU	20	0	
21	0	1 TUVU, 1 NOHA	21	0	PIWO calling
22	0		22	0	
23	0	1 TUVU	23	0	
24	0		24	0	
25	0		25	0	
26	0		26	0	
27	0		27	0	
28	0		28	0	
29	0		29	0	probable SSHA
30	0		30	0	

Appendix B

Table B1: Summary of the species of tree to which each nest box was mounted to, the land cover of the field adjacent to each nest box, and relevant notes on the use of that nest box.

Box Name	Tree Species	Land Cover	Notes
NB01	Red Maple	Corn	Great Crested Flycatcher nest
NB02	American Elm	Corn	Owl pellet
NB03	Green Ash	Fallow	Gray squirrel nest
NB04	White Pine	Corn	No activity
NB05	White Pine	Corn	No activity
NB06	American Elm	Hay	Gray squirrel nest
NB07	Red Maple	Corn	No activity
NB08	American Elm	Corn	Abandoned European Starling nest
NB09	Green Ash	Grass	European Starling at box, no evidence of nesting
NB10	American Elm	Hay	Gray squirrel nest
NB11	Quaking Aspen	Corn	Used by Tree Swallows
NB12	Green Ash	Fallow	Used by Great Crested Flycatchers
NB13	Quaking Aspen	Corn	No activity
NB14	Snag	Grass	Nest box fell, snag broke

Appendix C



The University of Vermont
Rubenstein School of Environment and Natural Resources

To whom it may concern,

My name is Grace Yaros, and I'm a sophomore at the University of Vermont studying wildlife and fisheries biology. I'm currently working on my honors thesis project involving American kestrel nest boxes, and am looking for properties on which to set up these boxes.

American Kestrels are North America's smallest falcon, and their populations have been declining in recent decades. Kestrels inhabit open grasslands, hunting insects and small mammals. Their decline is thought to be a result of the loss of these open grasslands to development and the succession of these areas from open grasslands to forests. Availability of nesting sites is also thought to contribute to their decline. Kestrels nest in tree cavities and they will readily take to nest boxes that mimic natural cavities. The goal of my project is to set up 10 nest boxes in areas with no recent documentation of kestrels with the hope that these nest boxes will encourage kestrels to nest in otherwise suitable habitat.

My project will require these nest boxes to be mounted to a tree or building. I will be setting up the nest boxes this summer so that birds migrating south this fall and young birds leaving their nests this summer can recognize them as potential future nesting sites. The actual data collection will occur next summer, meaning that the boxes will need to be up for at least one year. I'm hoping to set up the boxes by the end of June.

I hope that you might be interested in hosting a Kestrel nesting box on your property. Not only is this an excellent way to be involved in a local conservation project, but kestrels are phenomenal birds and skilled hunters that can also help control grasshopper and small rodent populations.

Contact information for myself and my advisor Dr. Allan Strong can be found below. If you are willing and able to have a nest box on your property, please reach out to me and we can find a time that works for you to get them set up! Feel free to reach out with any questions.

Sincerely,
Grace Yaros

Grace Yaros
Email — Grace.Yaros@uvm.edu
Cell Phone — (908) 962-0204

Allan Strong
Email — Allan.Strong@uvm.edu
Phone — (802) 658-6368



George D. Aiken Center, 81 Carrigan Drive, Burlington, VT 05405-0088
Phone: (802) 656-2911 Fax: (802) 656-8683 Web: www.uvm.edu/rsenr
Equal Opportunity/ Affirmative Action Employer 

Figure C1: Letter given to landowners describing the American Kestrel nest box project and asking permission to install a kestrel nest box on their property.